

# Facial Recognition Electronic Class Sign F2153 instructions



Bozztek Technology ( Shenzhen ) Co., Ltd.

Release version: V1.1

# Description of the F 2153 Electronic Class Sign with Facial Recognition Technology

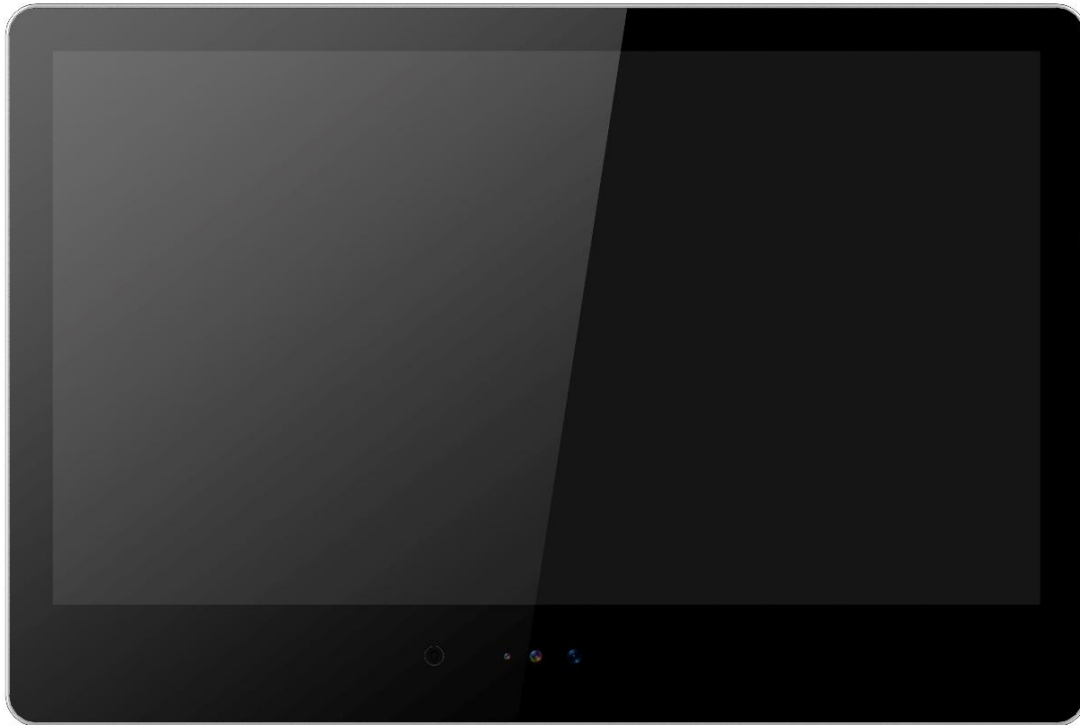

## 1 .application scenarios

Suitable for corporate, school, training institution, hospital, and administrative unit signage as well as access control scenarios.

## 2 .product features

- Wide dynamic binocular camera with live body monitoring capability;
- Efficient infrared supplementary lighting;
- Temperature monitoring function module is optional;
- Optional human motion detection module;
- Optional external NFC card reader and ID card reader are available.
- Supports deployment methods for public networks and local area networks, with optional 4G communication modules.

- Optional cameras include A200 and D2 models.

### 3 .Product Specification Sheet

Facial Recognition Electronic Class Sign				
product model		F 2153		
screen	size	21.5-inch Full View		
	resolution ratio	1920* 1080G+G capacitive multi-touch screen		
camera	type	RGB	infrared	
	resolution ratio	2 million pixels	1.3 million pixels	
	iris diaphragm	F2.4	F2.4	
	focal distance	4.8MM	4.8MM	
	white balance	voluntarily	voluntarily	
	Wide Dynamic	support	support	
	Vertical wide-angle			
		Horizontal wide-angle		
	Basic Specifications		operating system	Android 7.1 BOZZ OS
		processor	3288 A17*4 core processor with 1.8GHz clock speed and Mali T764 GPU	
memorizer		2G DDR+32 G EMMC		
device power supply		DC 12 V/3 A		
Device power consumption		26.2 Max		
relative humidity		0% -90% (in the absence of condensed water droplets)		
working temperature		0°C ~ 45°C		
Storage temperature		-20°C ~ 70°C		

	service environment	indoor	
	Device size	522mm*348mm*28mm	
	RM	human face /NFC	
	joggle	USB Type-A * 2	
		RJ45 LAN port *1	
		M ini-USB debugging port*1	
		DC power port*1	
		Supports Micro TF card slot* 1, up to 64GB	
		3.5mm headphone jack * 1	
loudspeaker	2W* 2		
temperature screening	Optional (requires custom procurement)		
essential parameter	WIFI	2.4G supports IEEE 802.11b/g/n	
	PDA	Supports Bluetooth 2.1/3.0/4.0/4.2	
	communication mode	4G full-network compatibility (optional: requires customized procurement)	
Package parameters	weight	7.5 Kg	
	size	645*408*105 mm	

#### 4 .F2153 Electronic Class Signboard Diagram

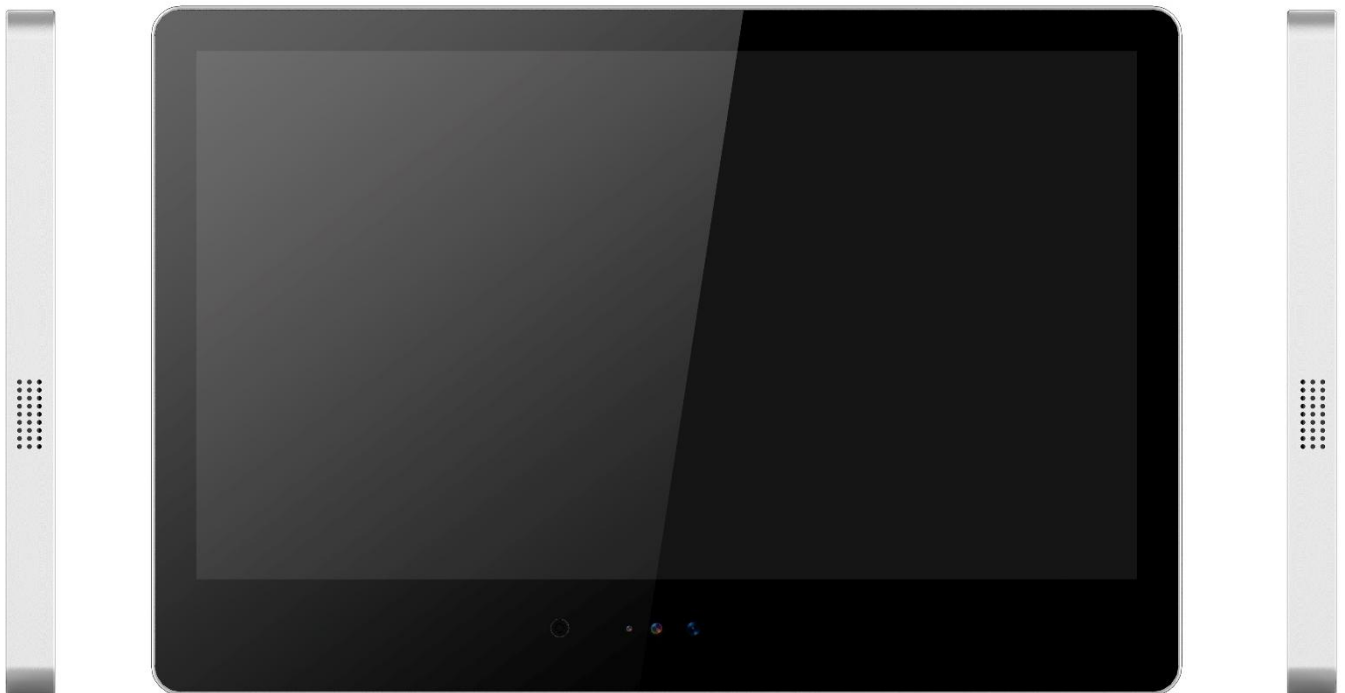

## 5 .F2153 Shape and dimensions (522\*348\*28mm)

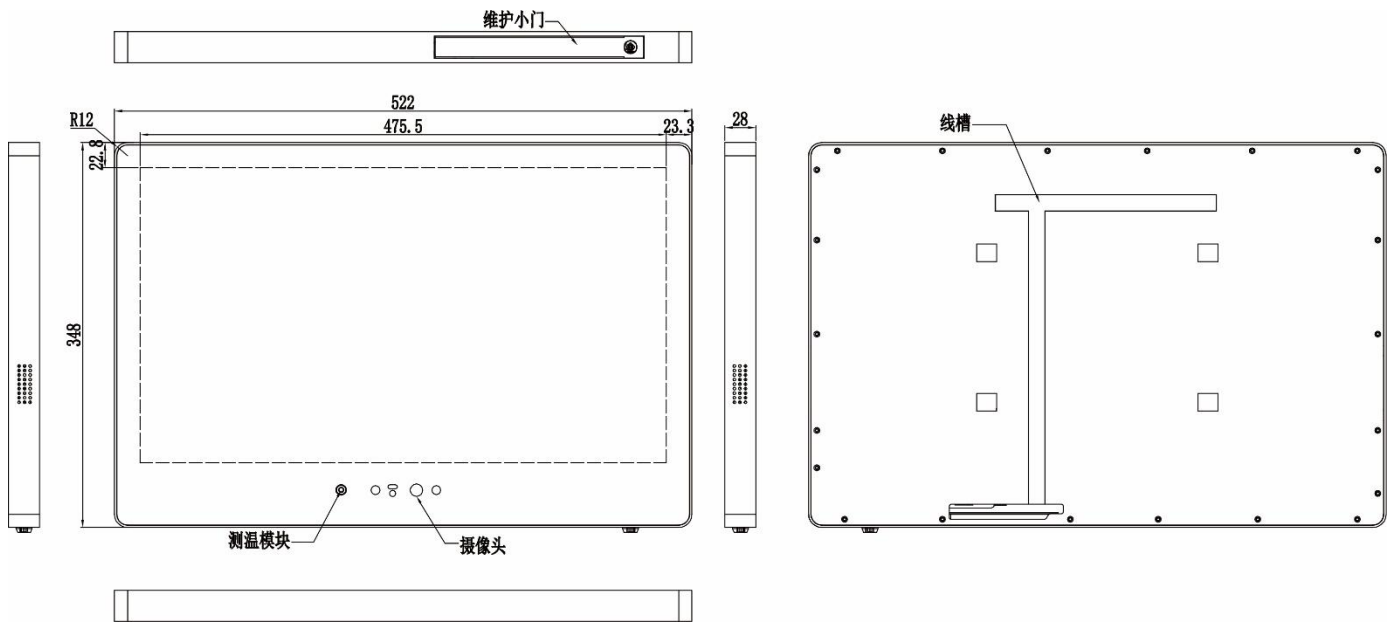

## 6 .Description of the front part of the F 2153 electronic class sign

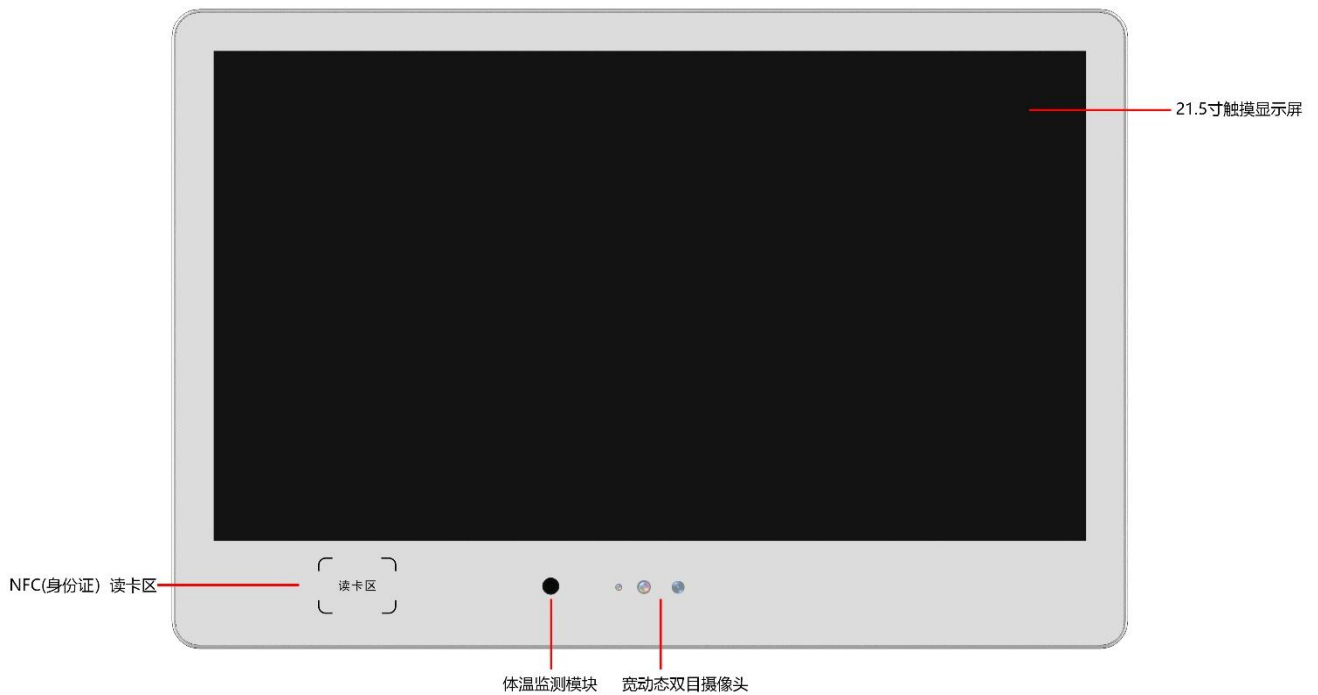

## 7 .Installation Instructions for F 2153 Electronic Class Signage

①Dimension specifications for wall-mounted brackets;

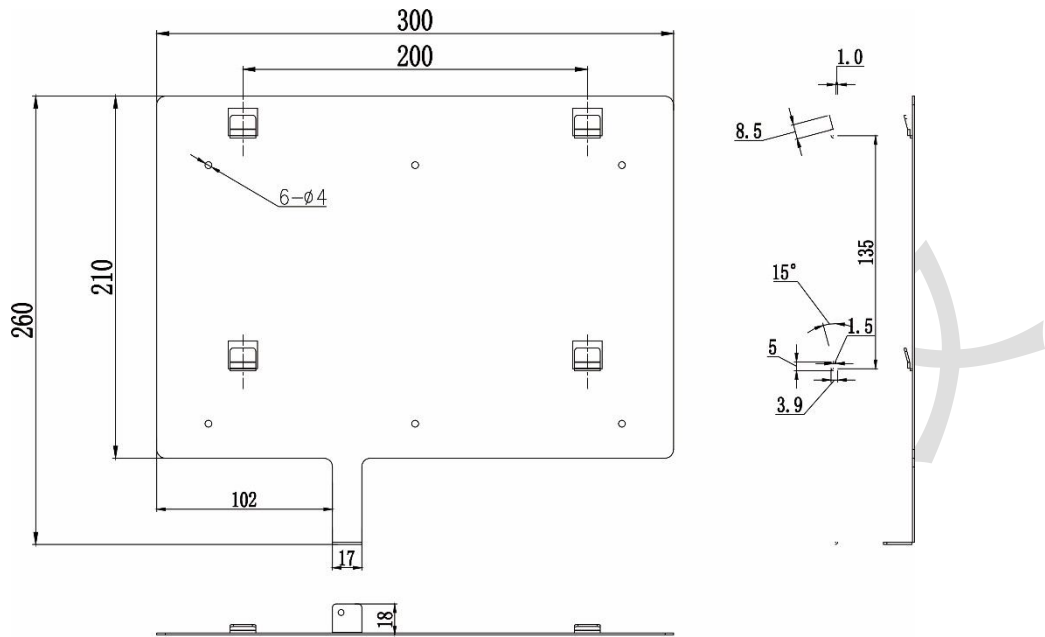

②Instructions for the installation position of wall-mounted brackets;

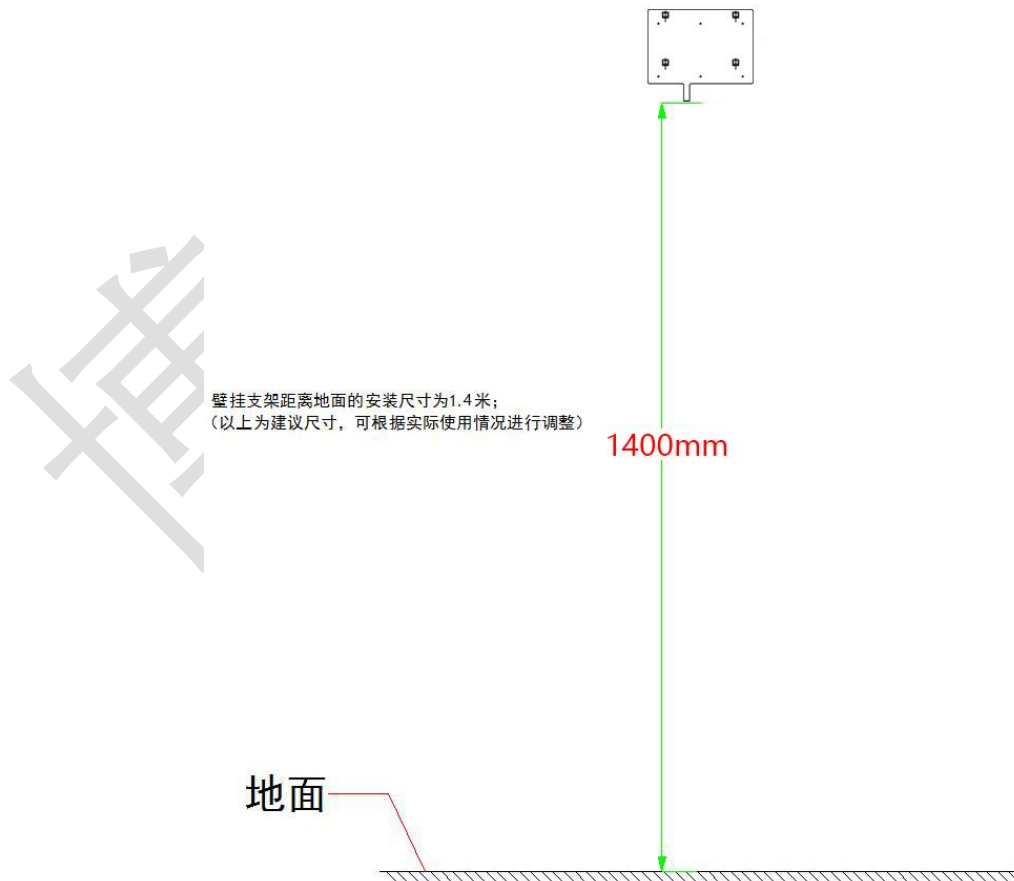

③ Fixation method between wall-mounted bracket and product terminal;

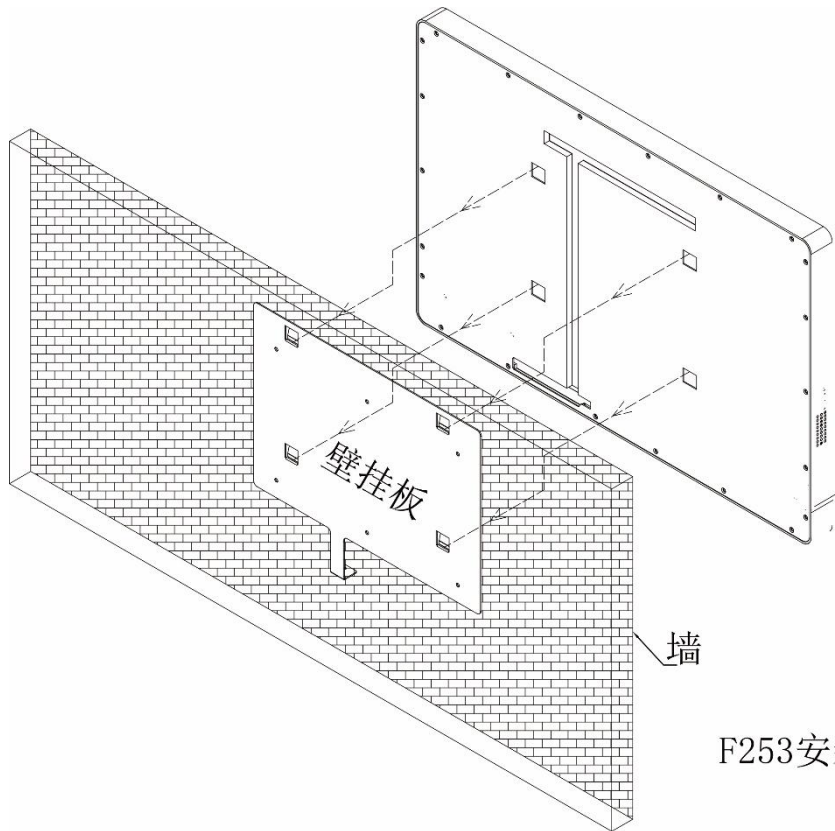

F253安装示意

## 8 .Electronic class sign packaging and usage instructions

### (1) List of Materials/Tools

order number	Material/Tool Name	dosage	explain
1	Host and built-in accessories	1	Included accessories: 12V adapter, wall mounting bracket, installation screws, interface door lock key, desiccant, etc.
2	Door switch (optional: requires external purchase)	1	Use when going out (not required if already equipped)
3	Ethernet cable (optional: requires external purchase)	a surname	For Ethernet and other residual wiring deployment
4	Wire clamp, network tester, bevel pliers, electrical tape, wire clip	a surname	For Ethernet and other residual wiring deployment

	(optional: requires external purchase)		
5	Drilling tools (optional: externally sourced)	a surname	For installing equipment and routing cables

## 9 .Installation Notes

1. During actual wiring installation, if the host computers 12V power supply line does not utilize a "dedicated power extension cable" and has an excessively long distance, resulting in excessive cable equivalent resistance, abnormal phenomena such as insufficient terminal voltage ( $\leq 11V$ ), repeated host restarts, and system crashes may easily occur.
2. The installation environment must be absolutely dry, and strong electric currents as well as strong electromagnetic fields should be avoided. Electromagnetic appliances and mobile devices such as smartphones should be kept as far away from equipment as possible.
3. This product is a precision device. Avoid collisions, drops, and vibrations to prevent detachment of motherboard components or internal camera damage, which may lead to functional or performance issues.
4. The installation environment must be absolutely dry, and strong electric currents as well as strong electromagnetic fields should be avoided. Electromagnetic appliances and mobile phones, which can be moved freely, should be kept as far away from the equipment as possible.
5. The equipment comes with a built-in power adapter as shown in the figure, with a total length of 1.8 meters.
  - The power cord extension should not exceed 3 meters, as exceeding this length may cause insufficient voltage supply to the devices main unit, resulting in abnormal phenomena such as repeated restarts and system crashes.
  - Using other adapters (e.g., 9V/1A) may cause repeated device restarts due to insufficient voltage or low current.
  - The cables used should not be too thin (e.g., thin Ethernet cables). It is recommended to use parallel multi-strand cables of the same type or thicker copper-core cables to ensure

a voltage > 11V.

Note: If using a network cable, use a 4-core extension cable with the four cores serving as the positive and negative terminals.

- If you are unsure how to extend the power supply, contact the supplier to replace it with a dedicated power extension cable.

## **10 .Select accessory specifications and installation instructions**

Development Description of Optional Human Body Temperature Measurement Module

### **Chapter 1: Introduction to Human Body Temperature**

Generally speaking, human body temperature remains relatively constant except for disruptions caused by various illnesses, particularly conditions like colds and fevers. While individual variations exist—some individuals may have slightly higher or lower temperatures—it typically stays around 36 degrees Celsius. However, microscopic analysis reveals that daily body temperature fluctuations are minimal and often imperceptible. Lets explore this concept in detail. In daily life, its crucial to recognize that body temperature isnt static; daily routines and environmental factors significantly influence its patterns. Essentially, body temperature remains relatively stable under normal circumstances. Therefore, monitoring temperature readings can help track health conditions and predict potential illnesses. Human body temperature maintains relative stability, with normal individuals experiencing minor fluctuations within 24 hours (typically not exceeding 1 degree Celsius). Physiologically, morning temperatures are slightly lower than afternoon readings. Post-exercise, after meals, during premenstrual or pregnancy periods in women, and in the elderly, body temperature tends to be slightly elevated. A temperature above normal is termed fever: low-grade fever ranges from 37.3–38°C, moderate fever from 38.1–39°C, high fever from 39.1–41°C, and hyperpyrexia exceeding 41°C. Maintaining stable body temperature is essential for sustaining normal physiological functions, such as regulating metabolism and immune responses. When body temperature exceeds 41°C or drops below 25°C, it can severely impair the functional activities of various systems (particularly the nervous system) and even pose life-threatening risks. The bodys heat production and

dissipation are regulated by the central nervous system, and many diseases can disrupt normal thermoregulation mechanisms, leading to temperature fluctuations. Clinically, monitoring patients body temperature and observing its changes plays a crucial role in disease diagnosis and prognosis assessment. Normal Body Temperature Range: Daily variations exist in body temperature across different regions and between genders. While maintaining a relatively stable range, normal human body temperature is not constant. Forehead surface temperature typically ranges from 35.0°C to 36.6°C, significantly influenced by environmental factors and measurement distance. Oral temperature (also known as mouth temperature) measures 36.2°C to 37.2°C, while axillary temperature is 0.2°C to 0.5°C lower than oral temperature. Rectal temperature (anal temperature) is 0.2°C to 0.6°C higher than oral temperature. Daily temperature patterns show lowest readings between 2:00 AM and 5:00 AM, peaking between 5:00 PM and 7:00 PM, with daily temperature variations generally under 0.8°C. Women typically exhibit approximately 0.35°C higher body temperature than men. Menstrual cycle fluctuations and hormonal changes during pregnancy may also affect temperature readings. Under healthy conditions with balanced diet and appropriate clothing, human body temperature remains relatively stable, maintaining around 37°C. Human body temperature typically ranges between 36°C and 37.2°C, remaining stable regardless of external environmental temperature fluctuations. The normal body temperature averages 36-37°C (axillary measurement), with readings exceeding this range indicating fever: below 38°C is low-grade fever, while above 39°C constitutes high fever. As evident from the above information, an individual's body temperature varies throughout the day and night, with temperature differences observed across different body regions. Therefore, absolute standards do not exist universally. Understanding these physiological principles enables individuals to better assess their health status and facilitates timely medical intervention when symptoms arise. Consequently, human body temperature should never be overlooked.

## **Chapter 2: Principle of Body Temperature Monitoring Function for F 2153:**

The F 2153 is a high-performance intelligent facial recognition device with extensive expansion interfaces. It integrates a 3D structured light camera and a far-infrared temperature monitoring module, featuring an aluminum casing for aesthetic and robust design. This device is widely applied in various scenarios such as facial recognition access control systems and turnstiles, enabling simultaneous facial recognition and body temperature monitoring of individuals.

Principle of far-infrared thermal sensors: Charged particles within any object are in constant motion. When an object's temperature exceeds the thermodynamic temperature of  $0^{\circ}\text{C}$  ( $-273^{\circ}\text{C}$ ), it continuously emits electromagnetic radiation into its surroundings. Spontaneous radiation from objects primarily manifests as infrared radiation at room temperature—commonly known as infrared light—which is invisible to the human eye but possesses intense thermal effects, hence also referred to as thermal radiation. The characteristics of thermal radiation are primarily determined by temperature, thus termed temperature radiation, forming the foundation of optical temperature sensing. The F2153 sensor specifically utilizes the energy emitted by human bodies to determine the surface thermal equilibrium temperature of target objects.

As introduced in the previous chapter, the human body maintains a constant internal temperature around  $37^{\circ}\text{C}$ . According to thermodynamic principles, the body achieves thermal equilibrium with the environment through various mechanisms including conduction, radiation, convection, and evaporation, ensuring stable body temperature. For instance, wind exposure induces a cooling sensation (due to heat dissipation through air convection), necessitating additional clothing for warmth. During extreme heat, sweating occurs (through evaporation). The F2153 system utilizes far-infrared thermal sensors to detect skin surface temperature, transmitting data to upper-layer applications for cloud-based analysis and monitoring.

Since thermal radiation energy from the human body is monitored based on surface temperature, precise temperature measurement requires specific requirements for both the installation environment of the equipment and the subject being measured. The details are as follows:

1. As introduced in the previous chapter, an individual's body temperature may exhibit variations within 1 degree across different physiological states, such as after intense exercise, during menstruation, or pregnancy. Therefore, F2153 serves solely as an intelligent tool for rapid body temperature screening and is not a medical diagnostic device. The collected data should not be used as definitive medical conclusions and is intended for reference only. In cases of identified high fever patients, personnel identification and early warning systems can be activated, followed by re-measurement or assessment of axillary or oral temperatures for further screening.
2. Prior to measurement, the subject must maintain emotional stability and avoid prolonged exposure of exposed skin to excessively hot (above body temperature) or cold (significantly below body temperature, e.g., 0°C) environments. This is because under such conditions, skin temperature may deviate from normal physiological levels due to air convection or external thermal radiation. While the temperature readings detected by F2153 are objectively accurate, they do not reliably reflect the subject's internal body temperature. If the subject has been exposed to extreme cold or heat for extended periods, recovery to normal physiological conditions should be ensured prior to measurement.
3. The equipment installation environment must be free from strong heat sources or intense convection (such as strong winds or air conditioning airflow), as these factors may affect the body temperature of individuals being measured. The optimal test environment temperature range is recommended to be between 10°C and 30°C. In environments exceeding human body temperature thresholds (e.g., 37°C or higher), while the measured body temperature data remains objectively valid, it loses clinical monitoring significance. Under strong convection conditions, air rapidly dissipates surface heat from the human body, resulting in underestimated surface temperatures that may lead to misjudgments by backend monitoring systems regarding the subject's actual body temperature.
4. The equipment installation site must maintain ventilation and an effective heat dissipation structure with adequate space. Excessive temperature difference between the equipment and its environment may affect measurement accuracy.